



AMU1-CHD+MK2
AUDIO MONITORING
UNIT

Handbook

TSL Products
Units 1-2, First Avenue, Globe Park, Marlow, Bucks, SL7 1YA
Telephone +44 (0)1628 564610

This Page is Blank

SAFETY

Installation.

Unless otherwise stated TSL equipment may be installed at any angle or position within an operating temperature range of 5° - 30°C.

All TSL equipment conforms to the EC Low Voltage Directive:

EC Low Voltage Directive (73/23/EEC)(OJ L76 26.3.73)(LVD). Amendment: (93/68/EEC) (OJ L220 30.8.93).

In all cases the chassis of the equipment must be earthed on installation.

The external power supply provided with this product may be one of two types:

1. A Class 2 double insulated type with a 'figure of eight' mains input connector.
2. A Class or Level 3 type with an IEC mains input connector. This type offers a functional earth and **NOT A SAFETY EARTH** via the earth pin of the IEC mains input connector to the outer of the co axial power connector or the pin nearest the pip on the Lemo style connector.

All metal panels are bonded together.

Check that the voltage selector setting (if fitted) and the fuse rating is correct for the local mains supply.

Due consideration for cooling requirements must be given when mounting the equipment. It is recommended that a 1RU of rack space, or a vent panel, should be left above and below the unit.

This unit requires rear support.

WARRANTY, MAINTENANCE AND REPAIR

All TSL equipment is guaranteed for one year from the date of delivery to the customer's premises. If the equipment is to be stored for a significant period, please contact TSL concerning a possible extended warranty period.

Failure during warranty

If any TSL product should fail or become faulty within the warranty period, first please check the PSU fuses.

All maintenance work must be carried out by trained and competent personnel.

If equipment has to be returned to TSL for repair or re-alignment, please observe the following overleaf:

TSL Returns Procedure

Please telephone +44 (0)1628 564610 and ask for Support who will provide a Returns Number. This will enable us to track the unit effectively and will provide some information prior to the unit arriving. Please do NOT return faulty equipment without first obtaining a returns number as this is likely to result in a delay in the repair of the equipment.

For each item, this unique Returns Number must be included with the Fault Report sent with the unit.

A contact name and telephone number are also required with the Fault Report sent with the unit.

Fault report details required.

- Company:
- Name:
- Address:
- Contact Name:
- Telephone No:
- Returns Number:
- Symptoms of the fault (to include switch setting positions, input signals etc):

Packing

Please ensure that the unit is well packed as all mechanical damage is chargeable. TSL recommends that you insure your equipment for transit damage.

The original packaging, when available, should always be used when returning equipment..

If returned equipment is received in a damaged condition, the damage should be reported both to TSL and the carrier immediately.

This Page is Blank

Contents

- 1.0 Introduction**
- 2.0 Front Panel Controls and Indicators**
 - 2.1 Input and Meter Selection Switches**
 - 2.2 Monitoring select Switch**
- 3.0 Pin-out Details**
 - 3.1 Analogue XLR Connectors**
 - 3.2 AES XLR connectors**
 - 3.3 Analogue Output connector – D25 Socket Pin out**
 - 3.4 AES Input/Output connector**
 - 3.5 DIP switch configuration functions**
- 4.0 Notes**
- 5.0 General Notes**
- 6.0 Specifications**
- 7.0 Front and rear view**
- 8.0 Block Schematic**

1.0 Introduction

The AMU1-CHD+ mk2 is a 1RU x 320mm deep Audio Monitoring Unit with two 26 segment bargraphs for audio level measurement.

The following features are standard:

- Two switch selectable stereo analogue inputs
- Four AES /EBU inputs
- Two HD/SDV auto sensing inputs
- Out-of-phase error indication
- EBU Digital and PPM metering scales
- Encoded PAL/NTSC composite or SDI output (Switch selectable)
- Re-clocked serial output of the selected input
- Integral loudspeaker system
- 40 Watt total amplifier power with 12VDC input
- Headphone outputs with LS muting
- Two 12V DC inputs
- Stereo /multi channel line outputs
- Two decoded AES outputs
- Variable line output

2.0 Front Panel Controls and Indicators

2.1 Input and Meter Selection Switches

Digital Source Select	Selects AES 1-2 and 3-4 (in conjunction with the channel switch) and SDI 1 & 2 Groups 1-4
Channel Select	Selects AES1,2,3 and 4 and pairs 1 (D1) and 2 (D2) from both the SDV inputs. Analogue 1 and 2 are also selected in position Anl 1 and Anl 2.
Meters	Left Channel is fed to the left bargraph and Right Channel is fed to the right bargraph.
Phase	Momentary phase reverse between A1 and A2 pairs. A non latching push switch with Red/Green LED indicates phase. Push to reverse.
Volume Control	Allows the audio level to be varied.

2.2 Monitoring select Switch

This switch allow stereo, Left, Right and Mono to be monitored from the internal loudspeakers and line outputs.
N.B. Position D is spare.

3.0 Pin-out Details

3.1 Analogue XLR Connectors

C	PIN	FUNCTION
ANALOG 1	1	GND
ANALOG 1	2	1 IN+
ANALOG 1	3	1 IN-
ANALOG 2	1	GND
ANALOG 2	2	2 IN+
ANALOG 2	3	2 IN-

3.2 AES XLR Connectors

C	PIN	FUNCTION
AES1	1	GND
AES 1	2	1 IN+
AES 1	3	1 IN-
AES 2	1	GND
AES 2	2	2 IN+
AES 2	3	2 IN-

3.3 Analogue Output Connector – D25 Socket Pinout on unit, Plug (shown) on mating cable.

D 25 SOCKET ON AMU	AUDIO OUTPUTS
PIN NO	FUNCTION
1	
14	
2	
15	
3	
16	
4	
17	
5	
18	
6	
19	
7	
20	
8	
21	
9	
22	
10	A2+ (FR)
23	A2- (FR)
11	Ground
24	A1+ (FL)
12	A1- (FL)
25	Ground
13	N/C

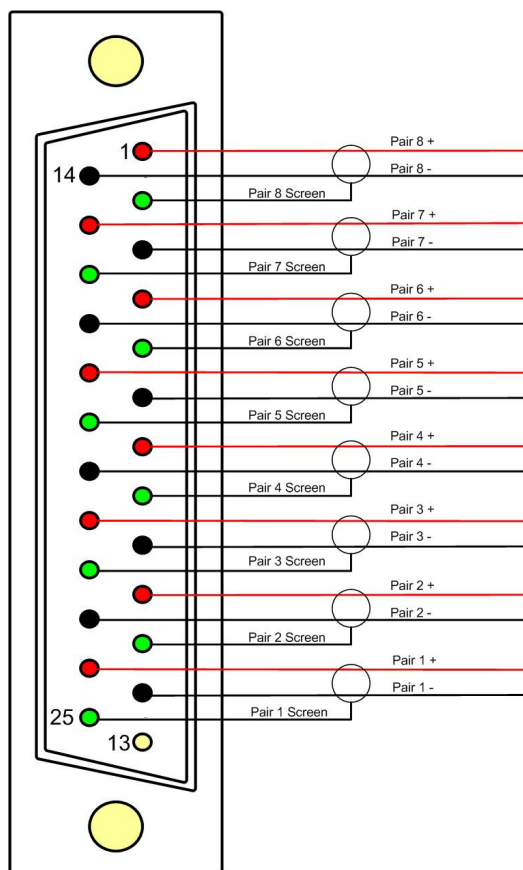

Note; this is a generic pin out, the outputs available are indicated in the table.

(N.B. These are analogue outputs of digital inputs)

3.4 AES Input/Output Connector – D25 Socket Pinout, Plug (shown) on mating cable.

D 25 SOCKET ON AMU	AES INPUTS/OUTPUTS
PIN NO	FUNCTION
1	Ch1&2 Input 1+
14	Ch1&2 Input 1-
2	Ch3&4 Input 2+
15	Ch3&4 Input 2-
3	Ch5&6 Input 3+
16	Ch5&6 Input 3-
4	Ch7&8 Input 4+
17	Ch7&8 Input 4-
5	Ch1&2 Output 1+
18	Ch1&2 Output 1-
6	Ch3&4 Output 2+
19	Ch3&4 Output 2-
7	N/C
20	N/C
8	N/C
21	N/C
9	N/C
22	Ground
10	Ground
23	Ground
11	N/C
24	Ground
12	Ground
25	Ground
13	Ground

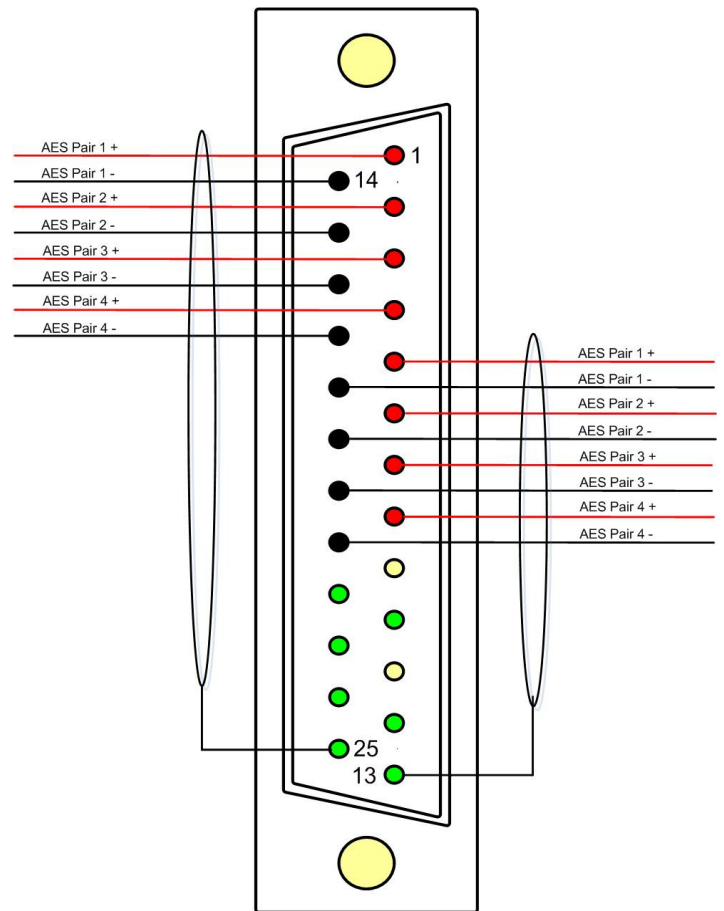

To use an unbalanced input pin 17 must be grounded. D-25 pins 10, 12, 17, 13, 22, 23, 24 and 25 are available for this purpose.

3.5 Configuration Switch Functions (subject to change, Y05 s/w)

SWITCH SECTION	FUNCTION
1	PPM – Up/ EBU Digital – Down
2	Peak Hold OFF-Up
3	Internal speaker Mute- Up
4	Calibration Level – see below
5	Calibration Level – see below
6	Calibration Level – see below
7	Not used
8	Composite out-Up/SDI \Down

The level configuration switches on the HDC2 board operates in a “2’s complement” manner the relationship between the dBfs level setting in the digital domain and the dBm level setting in the analogue domain. The “zero” position with all switches in the down position is designed to give 0dBm out for a level of -18dBfs in digital space. See below for configuration

SW4	SW5	SW6	FUNCTION
UP	UP	DN	-24dBFS
DN	UP	DN	-22dBFS
UP	DN	DN	-20dBFS
DN	DN	DN	-18dBFS
UP	UP	UP	-15dBFS
DN	UP	UP	TBD
UP	DN	UP	TBD
DN	DN	UP	TBD

(See Notes 4.0)

4.0 Notes

There are no user adjustable assemblies/components within this unit.

This unit requires rear support when rack mounted.

In order to affect status changes of the unit using the rear DIP switch, the unit will require re powering before the changes take effect.

Output analogue levels are adjustable over the following range:

0dBm = 0.775V into 600Ω i.e. 1mW power dissipation.

0dBu = 0.775V RMS = PPM 4.

Nominally, -18 dB ref 0FS = 0dBu output.

European line up : -18 dBu

American line: -20 dBu

5.0 General Notes

Please note that some American equipment has the function of the XLR pins 2 & 3 reversed.

TSL product is wired to the European standard

The screw locks on the D25 connectors use UNC 4-40 standard threads.

6.0 AMU1- CHD+mk2 Technical Specifications

Power Supply

Supply Voltage	12V DC
Power Consumption	50 watts.

Physical Dimensions

Height	44mm (1RU)
Width	483mm (19")
Depth	320mm
Weight	4500gm

Analogue Inputs 1 - 2

Connector Type	XLR Female 3 pin. Pin 1 Gnd, Pin 2 hot, Pin 3 cold.
Signal	Balanced line level audio.
Frequency Response	30Hz to 25kHz
Impedance	>20k Ω

Inputs AES 1, 2, 3 & 4

Connector Type	XLR Female 3 pin. Pin 1 Gnd, Pin 2 hot, Pin 3 cold.
Standard	AES3 (1994) at 48kHz, 44.1kHz or 32kHz
Impedance	110 ohm (balanced.)

Input, HD/SDV 1 & 2

Connector Type	BNC.
Standard	4:2:2 component with embedded 48Khz audio. (SMPTE 259M, 292M and 424M)
Impedance	75ohm

Line Output.

Connector	XLR 3 pin Male
Impedance	50 Ω
Output Levels	Through level control with 0dB gain.
Fixed Line O/P	Available on D25 (If selected on front panel)

Headphone Output.

Connector	Stereo Jack socket type A
Impedance	600 Ω
Output Levels	Through level control with 0dB gain.

De embedded output

Connector	25 way D type
Impedance	110 Ohm
Output	Groups 1, 2, 3 and 4

Video Output

Connector	BNC
Impedance	75 Ohm
Output	Composite video or SDI (selectable)

Re-clocked Output

Connector	BNC
Impedance	75 Ohm
Output	Re-clocked serial output of the SELECTED input HD/SDV

AES Output

Connector	AES I/O, 25 way D type (See section 3.4 for details)
Impedance	110 Ohm
Output	Selected SDI group.

HD Standards Supported

1080i/50
1080i/59.94
1080i/60
720p/50
720p/59.94
720p/60

Performance

Response	70Hz to 20KHz
Electrical Distortion	Better than 0.1%
Hum and noise	Better than -70dB
SPL	>98dB at 0.6 m
Amplifier Output	40 watts total power output
Digital Sample Rate	32 to 48KHz auto select

7.0 Front and rear view

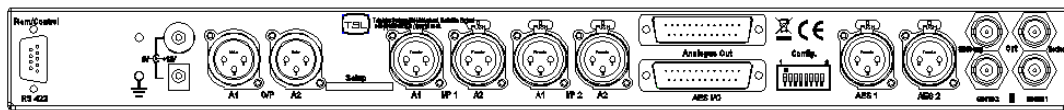
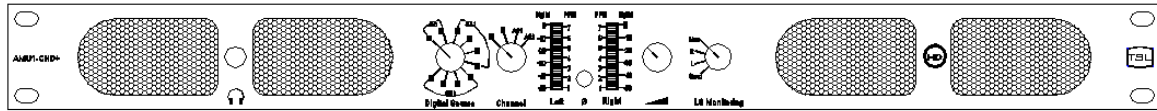

8.0 Block Schematic

